

HD3MDIP

EQUIP® SERIES 720P TDN INDOOR FIXED MINI-DOME NETWORK CAMERA

Honeywell's latest addition to the EQUIP® Series of IP-based products, the HD3MDIP is a high definition, True Day/Night indoor fixed mini-dome camera engineered to provide extremely crisp images at minimal bandwidth. The HD3MDIP provides 720p resolution at full frame rate. Progressive scan technology and 2D edge enhancement provide outstanding clarity and definition. Digital Noise Reduction results in significant storage savings without sacrificing image quality in low light. The 1/4" progressive scan CMOS sensor offers the latest in digital video surveillance technology with accurate color rendition through a wide variety of lighting conditions.

The compact, one piece design provides fast and easy installation in any application. The camera comes complete with surface and flush mounting options (compatible with a 4S electrical box) and an optional wall/pendant mount kit is available.

In addition to the low light color performance, the camera will automatically switch to black and white. In this mode, lighting can be complemented with infrared for discreet/covert low light surveillance with exceptional monochrome images.

A 3-D axis gimbal capable of 360° of pan, 180° of tilt and 360° of horizontal rotation simplifies mechanical camera adjustment. The Vari-focal Auto Iris lens allows the field of view to be adjusted to suit the scene requirements, and an onboard analog output allows the installer to connect a local test monitor while adjusting the scene.

A powerful and intuitive web client allows fine tuning of the camera and the auto iris levels. This can also be performed from most DVR/NVR setup utilities.

The HD3MDIP supports dual video streams and multiple compression formats with rates up to 30 frames per second (25 fps for PAL systems). The digital compression parameters for the two video streams are independently configurable. A third analog stream can be utilized for failover and local viewing, and is also valuable when retrofitting onto an existing analog input DVR or encoder (full resolution not available).

With built-in low current Power over Ethernet (IEEE 802.3af), Class 1, power is supplied to the camera using standard network cabling, eliminating the need for a separate power supply and associated wiring. In retrofit situations where PoE switching does not exist, the unit can also be powered directly from 24 VAC.

Market Opportunities

HD3MDIP is perfect for installations where excellent picture clarity at minimal bandwidth is required. At three times the resolution of standard analog cameras, yet with similar bandwidth requirements, HD3MDIP can be retrofitted on many existing DVR/NVR installations without requiring additional storage.

Features

- Outstanding image quality, 720p (1280 X 720) resolution
- 30 fps (25 fps PAL) progressive scan
- True Day/Night, 3.3-12 mm VFAI lens with removable IR cut filter
- Camera tamper detection
- Video motion detection
- Wall/pendant mount kit available
- Selectable compression formats
- Dual digital video streams simultaneously, independently configurable
- Remote firmware update
- Supports both dynamic and static IP address assignment
- Single model for surface mount and recessed ceiling applications, 4S adapter plate also supplied
- Includes advanced IP locator software to make system setup easy
- Web server for remote setup of camera video and network parameters
- Choice of 24 VAC or PoE IEEE 802.3af class 1 power inputs
- Supports input and output alarm contacts
- Supports bidirectional audio



HD3MDIP

www.honeywellvideo.com

SPECIFICATIONS

Like all cameras in the EQUIP Series, the HD3MDIP network camera uses Honeywell technology for camera video motion detection, tamper detection, remote firmware updating, and for secure storage of all camera settings. Video motion detection recognizes object motion within the field of view, then a simple on-screen notification alerts the user. Camera tamper detection notifies the user when a camera's field of view is altered, obstructed or blurred. This ensures the video's integrity and alerts the customer to either a live event or a system problem that is causing disruption to the video stream. Honeywell's technology also allows users to remotely upload firmware to the camera. Setup is quick and easy and can be customized through a web client or from an NVR or DVR. The built-in web server provides password protected access to the camera's video and network setup.

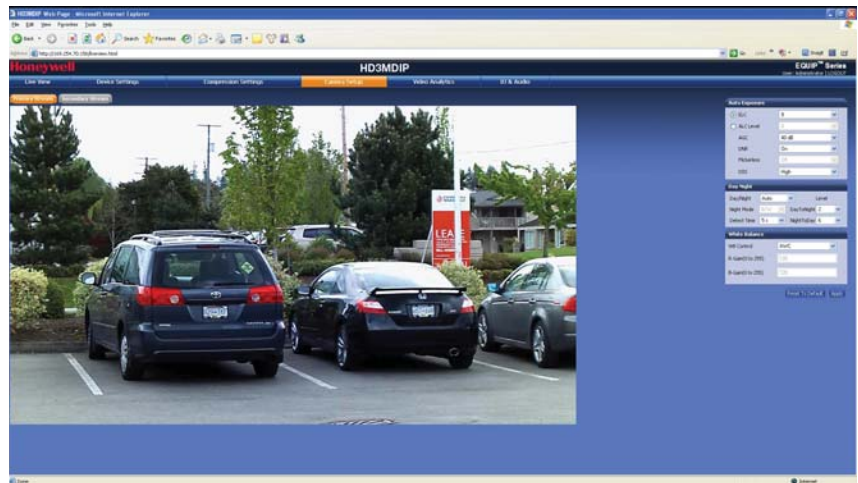

System Diagram

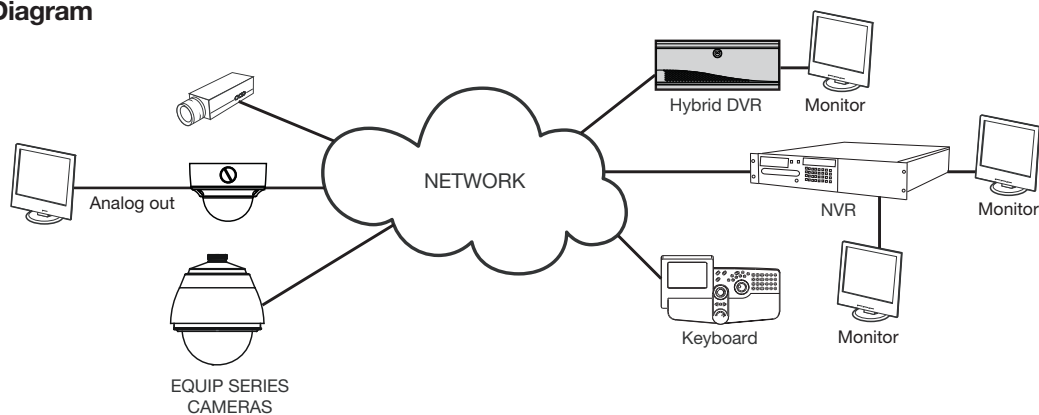

HD3MDIP

www.honeywellvideo.com

SPECIFICATIONS

Operational	
Video Standard	NTSC, PAL
Scanning System	Progressive scan
Image Sensor	1/4" CMOS
Number of Pixels (H x V)	1280 x 720
Minimum Illumination (DSS on)	0.25 lux color/0.22 lux for BW @ 50 IRE, F1.6 0.11 lux color/0.09 lux for BW @ 30 IRE, F1.6
Automatic Lens Control	DC Iris Level 1-25
Video Output (AUX)	1.0 Vp-p @ 75 Ohms
S/N Ratio	50 dB or more (AGC off)
Auto Gain Control	Off/On, selectable (10-40 dB)
Automatic Electronic Shutter	1/60-1/24,500 (NTSC) 1/50-1/24,500 (PAL)
Lens Type	True Day/Night (TDN), 3.3 mm-12.0 mm Vari-focal Auto Iris, F1.6
White Balance	AWC, AWC Push, Manual
Audio/Two-Way	Line in/out
Electrical	
Input Voltage	24 VAC, PoE IEEE 802.3af, Class 1
Input Range	17-28 VAC
Surge Suppression	1.5 kW transient
Power Consumption	3.5 W (max)
Mechanical	
Dimensions (W x H x D)	See Diagram
Weight	1.0 lb (.448 kg) camera only
Construction	Housing: Polycarbonate Finish: Matte texture, Off White
Connector	Video Output (AUX): 2-pin Molex connector Power Input: Removable screw block Network: RJ45 connector Alarm I/O: Removable screw block Audio In: Removable screw block Audio Out: Removable screw block

Environmental			
Temperature	Operating: 14°F to 122°F (-10°C to 50°C) Storage: -4°F to 140°F (-20°C to 60°C)		
Relative Humidity	0% to 85%, non-condensing		
IP Specifications			
Video Compression	Industry standard compression		
Resolution	Bitrate (Typical)*	Frame Rate	Storage/Day (GB)
1280 x 720	3 Mbps	30/25	31.64
800 x 450	2 Mbps	30/25	21.09
640 x 360	1 Mbps	30/25	10.55
320 x 180	0.35 Mbps	30/25	3.69
Frame Rate NTSC/PAL	Up to 30/25 fps		
Video Streaming	Dual streaming: Controllable frame rate and bandwidth Constant or variable bit rate		
Security	Multiple user access levels with password protection		
Users	1 Administrator, 1 Guest		
Video Access from Web Browser	Camera live view for up to 1 client Full control of all camera settings available to administrator		
Minimum Web Browsing Requirements	Pentium IV CPU 3.0 GHz or equivalent AMD, 512 MB RAM, AGP graphics card (32 MB RAM) Windows® XP 2000, Internet Explorer 6.0 or later		
Supported Protocols	HTTP, TCP, RTSP, RTP, UDP, ARP, DNS, RTCP, FTP, ICMP, DHCP, Bonjour, IGMP, Telnet		
Regulatory			
Emissions	FCC, CE (EN55022)		
Immunity	CE (EN50130-4)		
Safety	EU: 2006/95/EC LVD, UL 60950		

*Actual bitrate is scene and motion dependant.

HD3MDIP

www.honeywellvideo.com

SPECIFICATIONS

System Compatibility	
Honeywell Products	
Hybrid DVRs	
Fusion IV	v4.00.6401 or higher
NVRs	
Enterprise NVR Series	Enterprise Class Digital NVR System, version 5.75 build 17 or higher
MAXPRO VMS®/ IP Engine	Version R200 or higher
DVM	DVM R300 or higher
Fusion IV	v4.00.6401 or higher
Third-Party Products	
Refer to the Honeywell Open Technology Alliance for a comprehensive list of compatible products to which this device is integrated.	

Accessories	
Housing and Mounts	
HD3-MK	Wall/Pendant Mount Kit, Off White

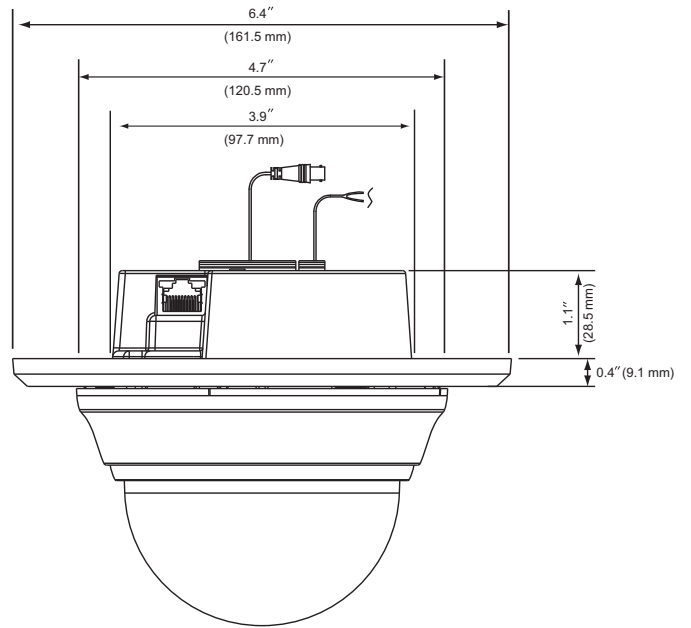
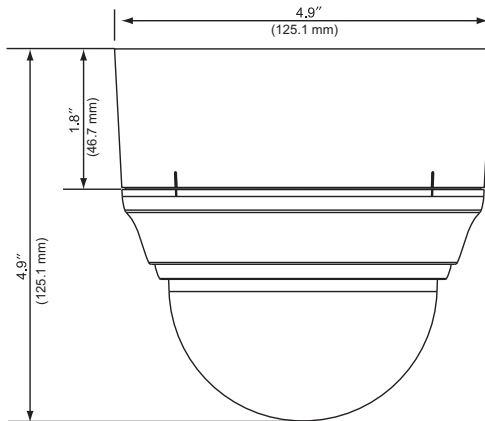

Ordering	
HD3MDIP	Network True Day/Night, 1/4" Progressive Scan, CMOS, 720p Resolution Camera, 3.3-12 mm VFAI, 24 VAC or PoE IEEE 802.3af, NTSC
HD3MDIPX	Network True Day/Night, 1/4" Progressive Scan, CMOS, 720p Resolution Camera, 3.3-12 mm VFAI, 24 VAC or PoE IEEE 802.3af, PAL

NOTE: Honeywell reserves the right, without notification, to make changes in product design or specifications.

Honeywell Security Group

Honeywell
2700 Blankenbaker Pkwy, Suite 150
Louisville, KY 40299
1.800.796.CCTV (2288)
www.honeywell.com

L/HD3MDIP/D
June 2010
© 2010 Honeywell International Inc.

Honeywell